

HIGH POWER LATCHING RELAY

- 90A Latching Relay
- UC2 capability as per IEC 62055-31
 - Rated Breaking Current (Ic) = 60A
 - Reference Voltage (Un) = 240V
 - Rated Breaking Voltage (Uc) = 276V
- 4kV dielectric strength between coil and contacts
- Outline dimensions: (38.1 x 30.0 x 16.5)mm
- Custom assemblies available with flex wire and/or copper extensions, and/or with integrated shunt
- UL 508 Compliant *
- RoHS compliant materials and process

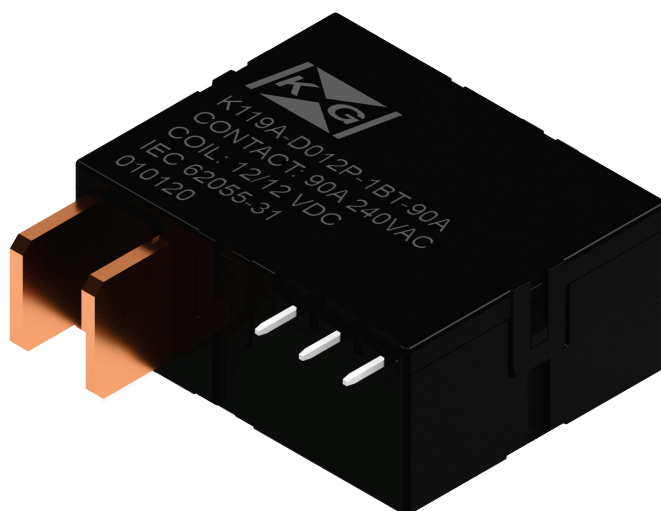

Contact Data

Rated Load †	60A @ 276V
Contact form	1A or 1B
Contact material	AgSnO ₂
Contact resistance ‡	0.7mΩ (at 80 A)
Max. switching voltage §	276 Vac
Max. carrying current	90 A
Max. switching current **	60 A
Rated switching power	16,560 VA
Set time	≤ 20 ms
Reset time	≤ 20 ms
Electrical endurance	10,000 cycles
Mechanical endurance	100,000 cycles

Characteristics

Insulation resistance	1,000MΩ (at 500 Vdc)
Dielectric strength:	
Coil to contact	4kVac for 1 min.
	10kV 1.2μs/50μs
Across open contacts	2kVac for 1min.
Dielectric creepage	8 mm
Ambient temperature	-40°C to +85°C
Ambient humidity	5% - 85% RH
Vibration	1.5 mm (DA) 10 Hz to 55 Hz
Shock resistance:	
Functional ††	98 m/s ²
Survival	980 m/s ²
Coil termination	PCB or Wire
Unit weight	100g

* Compliant to: UL 508; File Number: E133481

† Load at which the relay can pass UC2 as per IEC 62055-31

‡ Typical value for Initial Contact Resistance: Using a sample quantity of at least 20 units, take the average value from 5 continuous measurements from each sample

§ Voltage at which the relay can pass electrical endurance as per IEC 62055-31

** Current at which the relay can pass UC2 as per IEC 62055-31

†† Unit may change state but is still functional

Coil Data

	Single Coil (Latching)	Dual Coil (Latching)
Coil Consumption	1.5W	3W
Pulse Duration	50ms	50ms

Coil Resistance

($\Omega \pm 10\%$) at 23°C

Nominal Coil Voltage	Min Set/Reset Voltage	Single Coil (Latching)	Dual Coil (Latching)
5Vdc	3.5Vdc	16 Ω	2 x 8 Ω
6Vdc	4.2Vdc	24 Ω	2 x 12 Ω
9Vdc	6.3Vdc	54 Ω	2 x 27 Ω
12Vdc	8.4Vdc	96 Ω	2 x 48 Ω
24Vdc	16.8Vdc	384 Ω	2 x 192 Ω
48Vdc	33.6Vdc	1536 Ω	2 x 768 Ω

Ordering Information

	K119	■	-■	■	■	-■	T	-90	-Cxxxx
Relay Series									
Terminal Type:	A: See Drawing B: See Drawing C: See Drawing D: See Drawing E: See Drawing F: See Drawing X: Custom Design ^{##}								
Coil Type:	S: Single Coil D: Dual Coil								
Coil Voltage ^{§§} :	5, 6, 9, 12, 24, 48Vdc								
Polarity:	P: Positive N: Negative								
Contact Form:	1A: Form 1A – Normally Open (NO) 1B: Form 1B – Normally Closed (NC)								
Contact Material:	T: AgSnO ₂								
Contact Rating:	90: 90A								
Custom Number:	Cxxxx: Where xxxx represents a unique number for custom relay terminal designs								

^{##} For custom designs, please contact KG Technologies. Integrated shunts, flex-wire, copper extension and brass terminals available

^{§§} Coil voltage should be indicated in three-digit format (6Vdc = 006)

TYPE E CONTACT TERMINALS

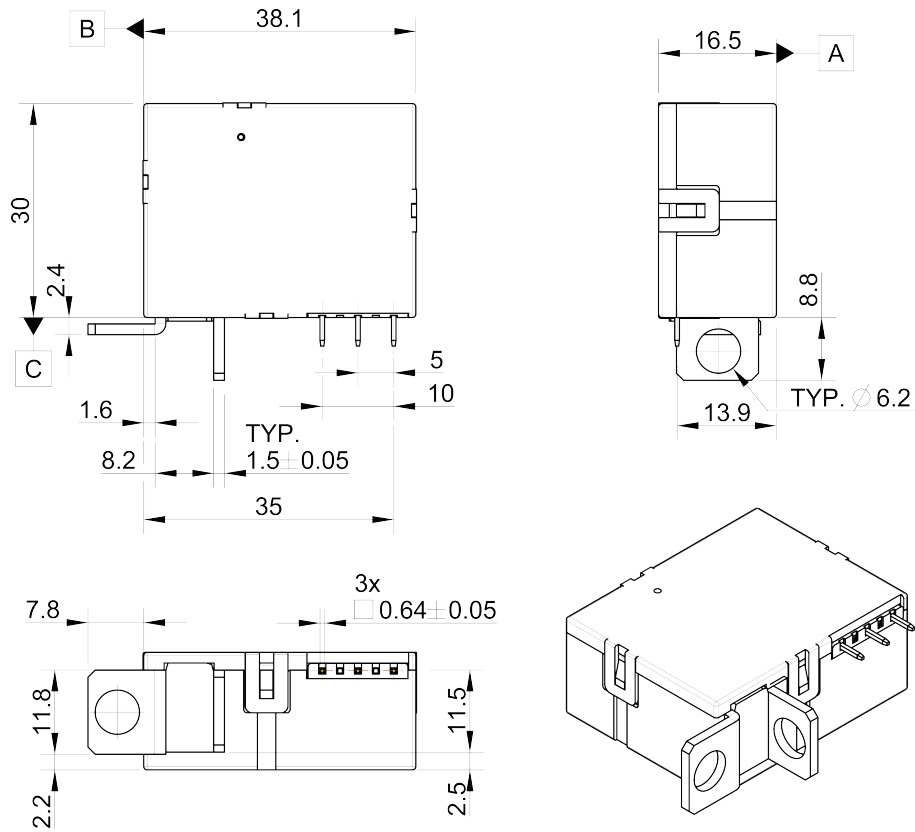

TYPE F CONTACT TERMINALS

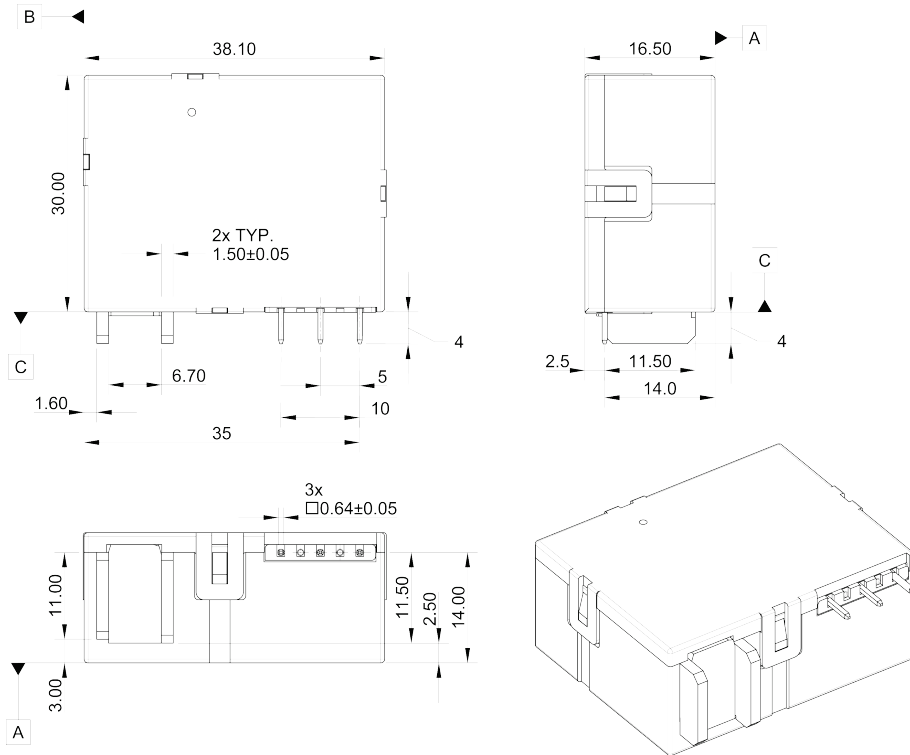

Coil Pin Configurations

(Unit: mm)

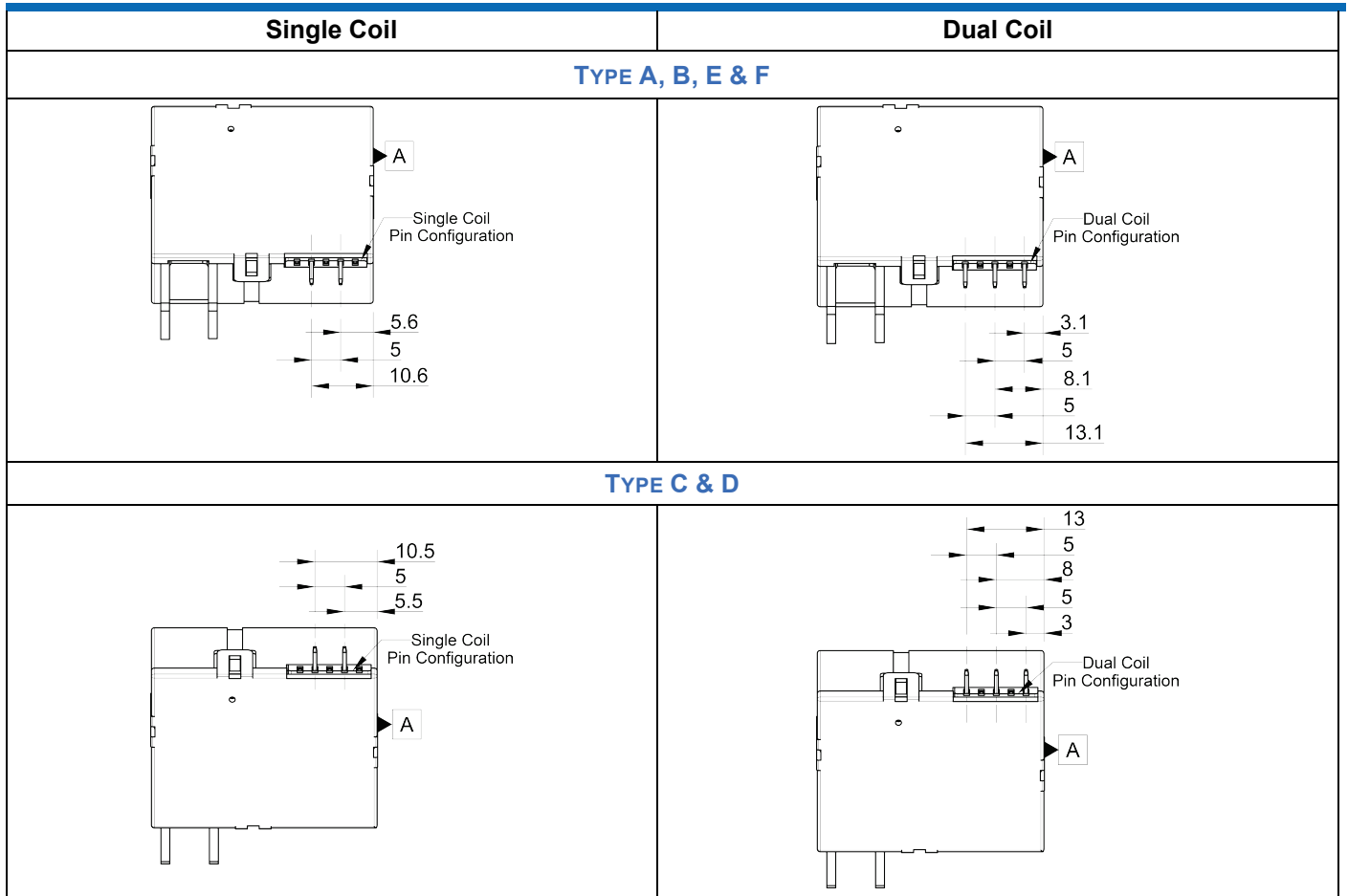

Wiring Diagrams

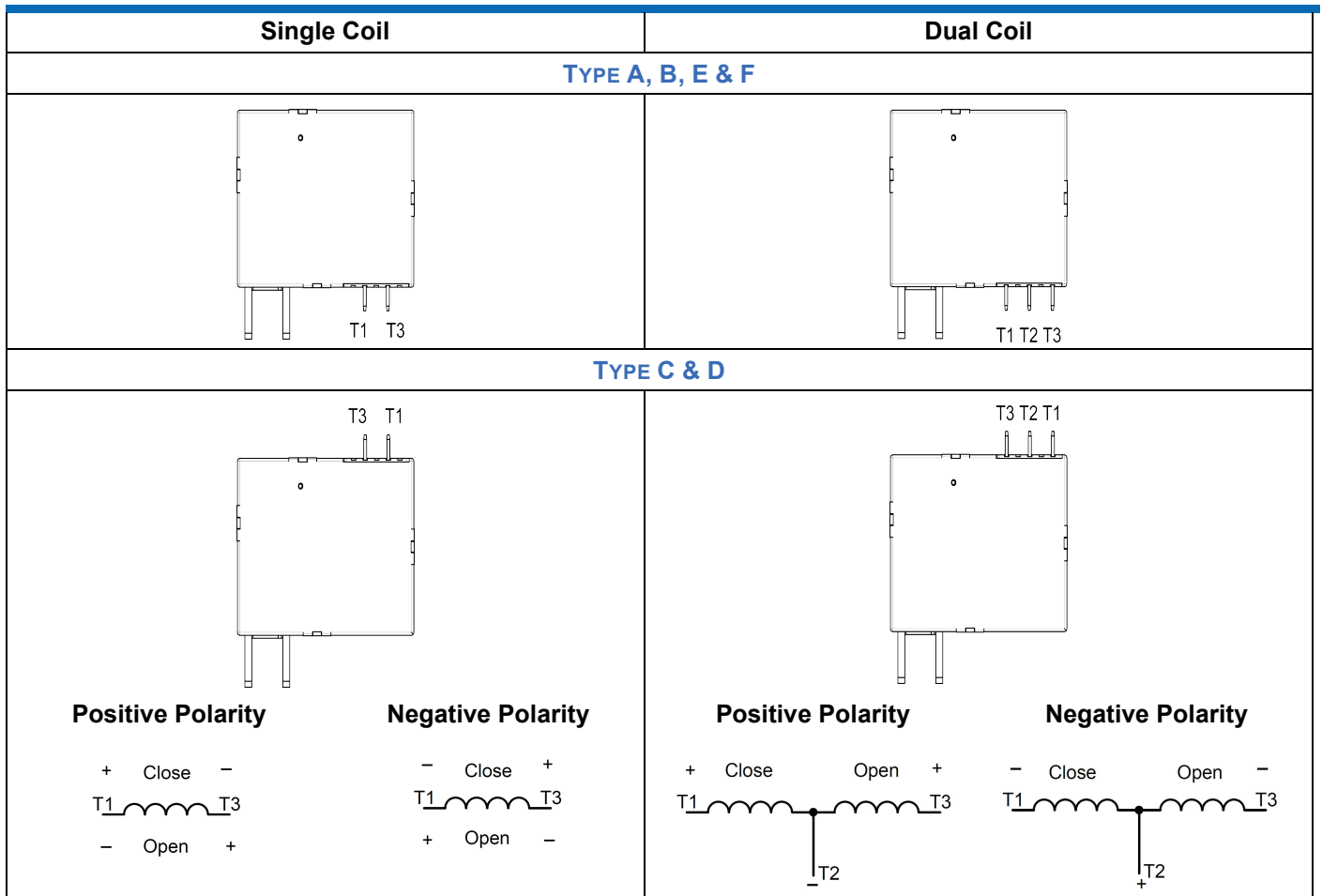

Application Notes

1. It is possible that during transit or final assembly the relay could change state. Therefore, it is recommended that all relays be set to the desired state via a power supply.
2. In order to maintain an “Open” or “Closed” state of the relay, the coil voltage should reach the rated voltage. The pulse width should be 50ms minimum to ensure a proper change of state. DO NOT energize both T1 and T3 at the same time on a Dual Coil or energize the coil for longer than 1 minute (damage to the coil could occur).
3. Applying excessive heat to the relay terminals (soldering or welding) can cause damage to the internal structure of the relay and should be avoided.
4. Moving or bending the terminals can cause damage to the internal structure of the relay and should be avoided.
5. For definitions of terms used in this data sheet, see [glossary](https://kgtechnologies.net/glossary) at <https://kgtechnologies.net/>

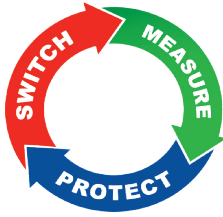

6028 State Farm Drive, Rohnert Park, CA 94928
Tel: +1.888.513.1874 Fax: +1.707.665.5966
Email: techinfo@kgtechnologies.net
www.kgtechnologies.net



Scan here for
more information

Disclaimer: This datasheet is for reference only. All specifications are subject to change without prior notice. KG Technologies, Inc. cannot predict every possible application for our relays. While we do our best to make our relays as versatile as possible, we highly recommend contacting our engineering team if you have any questions. KG Technologies, Inc. is not responsible for malfunctioning relays when operated outside the specified parameters given in this datasheet.